

# Pass og kutt

2 m Motion Dribble@  
SO PPA

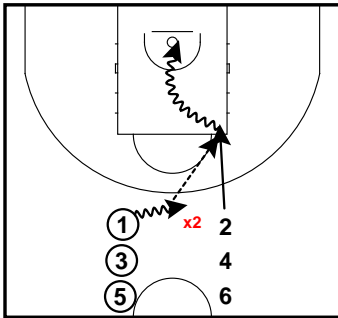

**Backdoor**

To rekker. 1 finter mot venstre, vender opp mot 2 og dribbler én gang. 2 kutter hardt backdoor. 1 utfører én håndspasning med utsidehånd. 2 mottar ball i jump stop. Retningskifte med ett sprett inn i avslutning på kurv.

2 m Motion Dribble@  
SO PPA

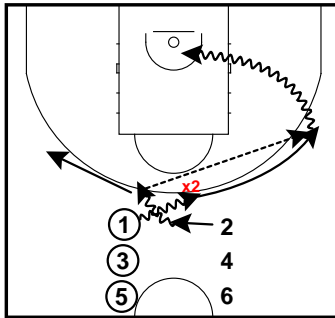

**Handoff, Flare, Rip & Go**

Liksom-forsvar X2 spiller av. 2 kommer inn i en handoff (denne situasjonen kaller vi "Hold"). 2 ser etter å angripe med ball mens 1 flarer til utsiden. 2 stopper i jump stop, gjør en reverse pivot og passer til utsiden av 1. 1 river og går baseline. 1 drifter 45 grader på toppen (DDA).

2 m Motion Dribble@  
SO PPA

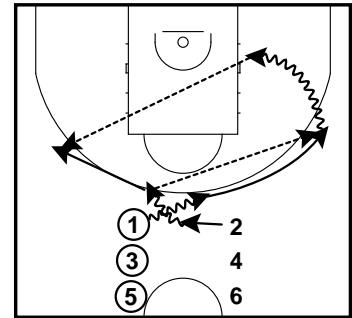

**Handoff, Flare, Rip & Go + DDA**

Samme som forrige, men 1 passer ballen over hodet til 2 som drifter på toppen.

2 m Motion Dribble@  
SO PPA

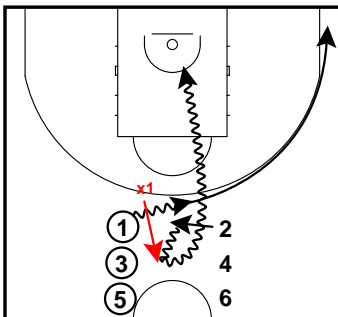

**Handoff, Flare, Drive denied**

Hvis X1 hedger hardt på handoff og blokkerer banen til drive: 2 kan gjøre to ting

- 1) Jump stop, reverse back pivot (drop step) tilbake og drive til kurven.
- 2) Retreat dribble ut, beskytte ball ved hofte, og snu dribbling tilbake for å angripe.

2 m Motion Dribble@  
SO PPA

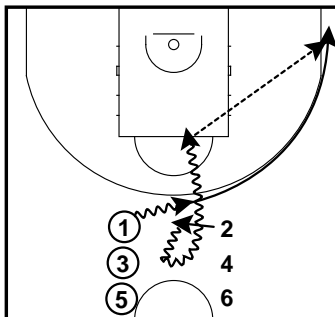

**Handoff, Flare, Drive denied + DDA**

Samme som forrige med pasning til skytter.

2v1 dribble@  
SO PPA

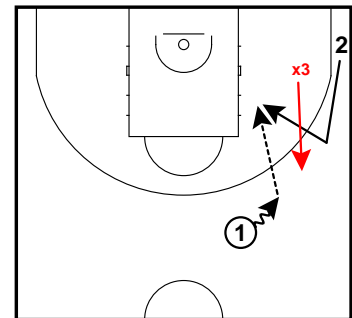

O2 will fill up from the corner. The dummy defender X3 will either deny or sag off. Deny = backdoor cut as in the diagram. Sagging defense = dribble hand-off as in the next diagram..

**Purpose of the drill:** work on 2-man cooperative movement in a dribble-at situation.

2v1 dribble@  
SO PPA

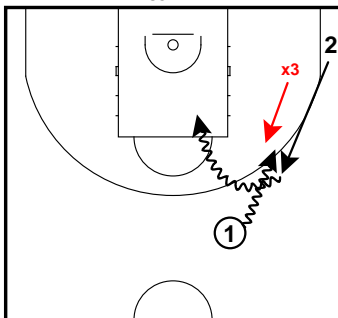

X3 may sag of which means a dribble hand-off.

2v1 Give & Go  
SO PPA

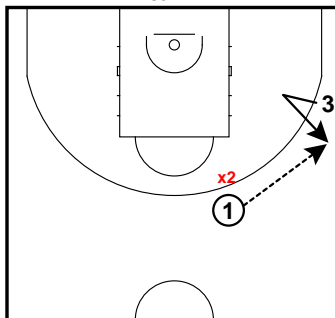

This drill works on simple give & go with dummy defense. When one of the offensive players pass they must read the defense and make the correct cut. The drill alternates between cuts from the top and from the wing.

**Purpose of the drill:** Work on basket cuts, passing and footwork (V-cuts, pivoting etc.).

2v1 Give & Go  
SO PPA

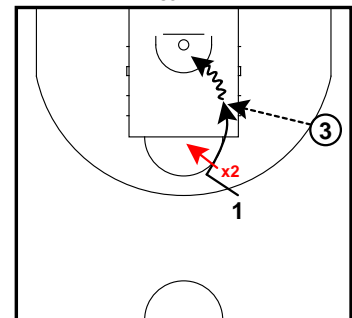

After O1 has made the pass to O3 he must set up the defense away from the ball. If the defense is on the wrong side O1 must front cut.

# Pass og kutt

2v1 Give & Go  
SO PPA

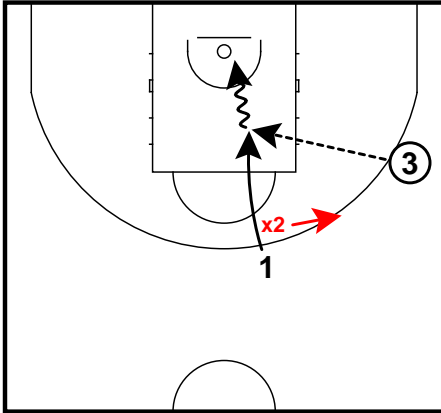

If X2 jumps to the ball O1 must back cut.

2v1 Give & Go  
SO PPA

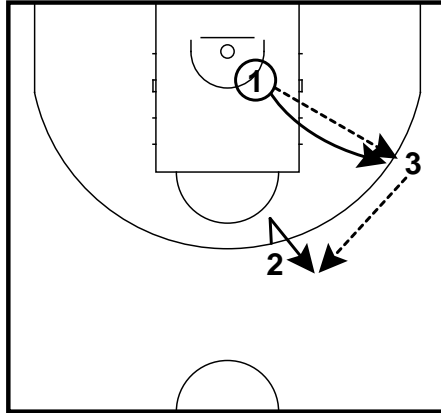

**Rotation:** Player that takes the layup catch the rebound, passes out to the opposite position and closes out to be the defense. Defense becomes offense after a basket cut.

3v0 pass & cut  
SO PPA

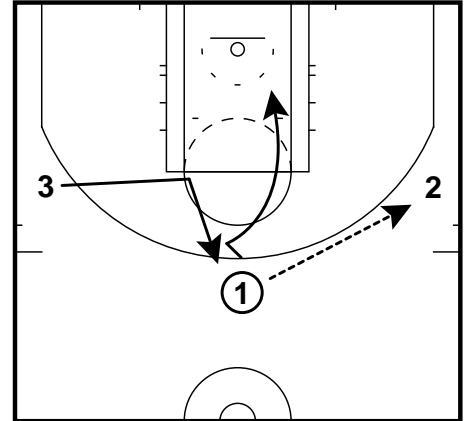

3v0 pass & cut  
SO PPA

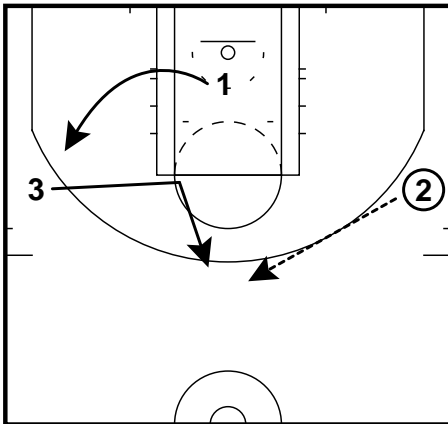

Pass & cut  
SO PPA

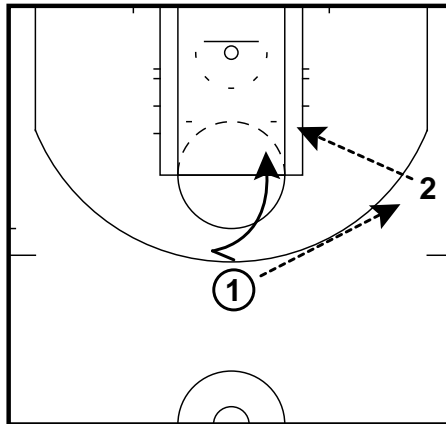

1 sentrer til 2, setter opp mann og kutter til kurv  
2 mottar ball og sentrer tilbake til 1 på kutten

Pass & cut  
SO PPA

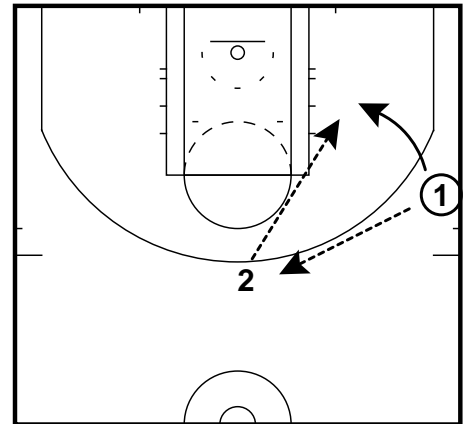

1 sentrer til 2, og kutter backdoor  
2 mottar ball og sentrer tilbake til 1 på kutten

# Dribble Drive Automatics

2m Dribble drive automatics  
SO Dribble Drive Automatics

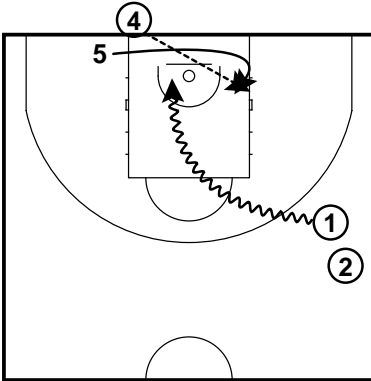

Weak side post

2m Dribble drive automatics  
SO Dribble Drive Automatics

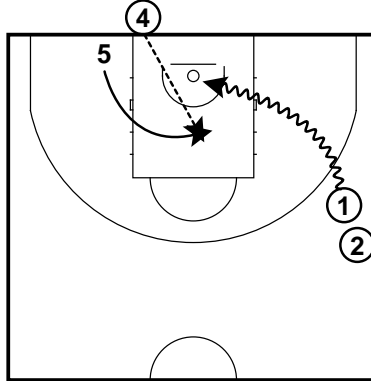

Strong side post

2m Dribble drive automatics  
SO Dribble Drive Automatics

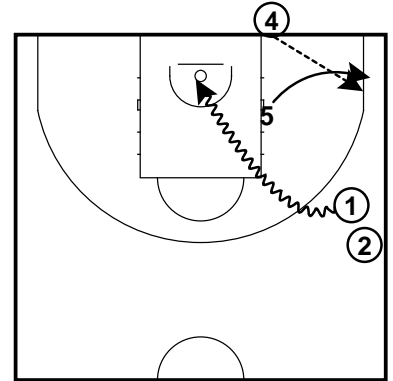

2m Dribble drive automatics  
SO Dribble Drive Automatics

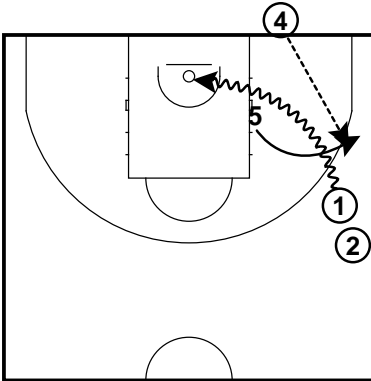

2m Dribble drive automatics  
SO Dribble Drive Automatics

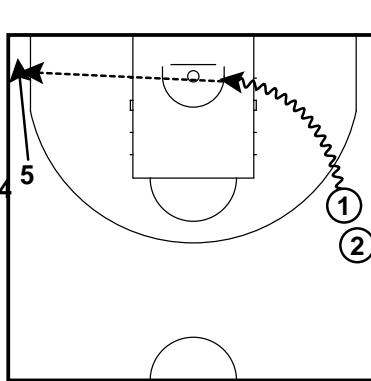

Baseline drift

2m Dribble drive automatics  
SO Dribble Drive Automatics

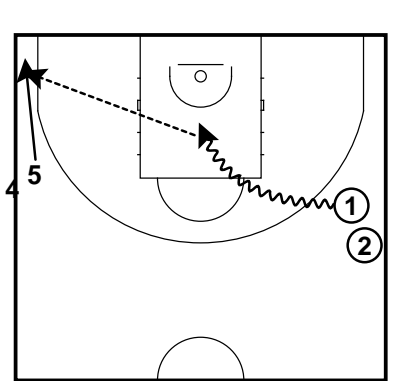

2m Dribble drive automatics  
SO Dribble Drive Automatics

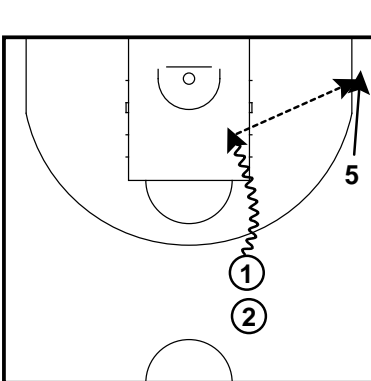

Strong side drive

3m Dribble Drive Automatics  
SO Dribble Drive Automatics

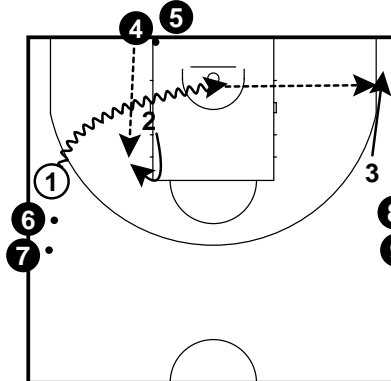

Strong side post

3m Dribble Drive Automatics  
SO Dribble Drive Automatics

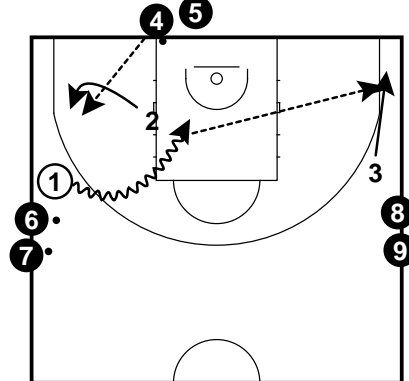

# Dribble Drive Automatics

3m Dribble Drive Automatics  
SO Dribble Drive Automatics

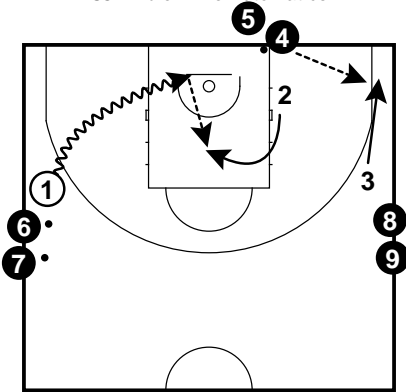

Weak side post

3m Dribble Drive Automatics  
SO Dribble Drive Automatics

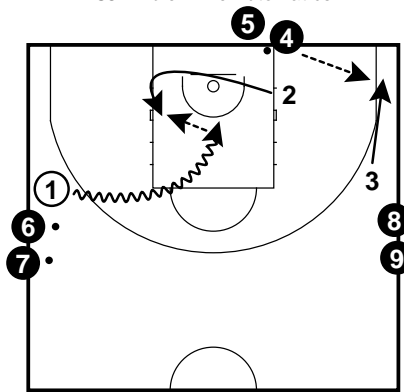

Weak side post

3m Dribble Drive Automatics Post Action  
SO Dribble Drive Automatics

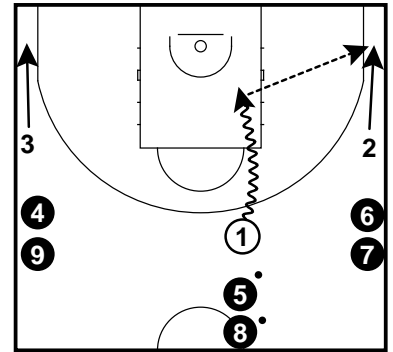

**Purpose of drill:** Work on dribble drive automatics with multiple drives. Players may drive in any direction. The players without the ball must move and be ready to shoot.

3m Dribble Drive Automatics Post Action  
SO Dribble Drive Automatics

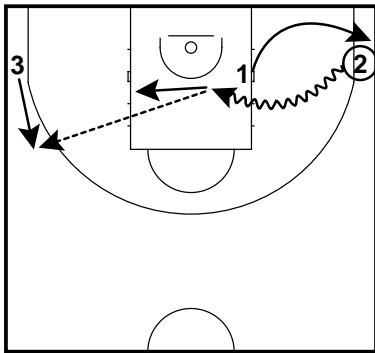

3m Dribble Drive Automatics Post Action  
SO Dribble Drive Automatics

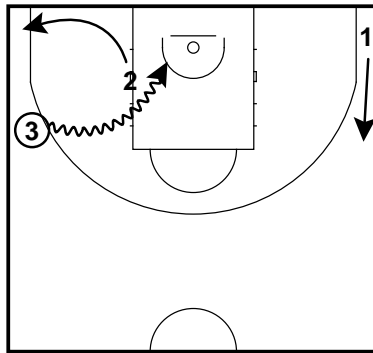

# Screen vekk fra ball

2v0 Backscreens  
SO Offball screens

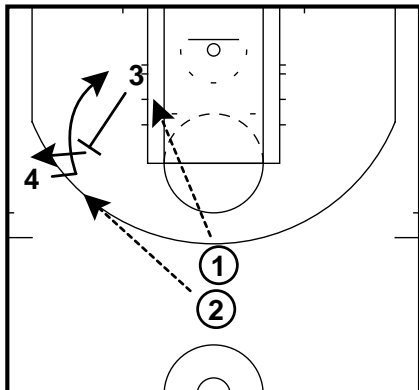

3 setter backscreen for 4. 4 setter opp man, kutter til kurv og får pasning av 1. 3 popper og får ball av 2, 3 skyter eller angriper kurv. 1 og 2 går annenhver gang til de andre rekkene.

2v0 Downscreens  
SO Offball screens

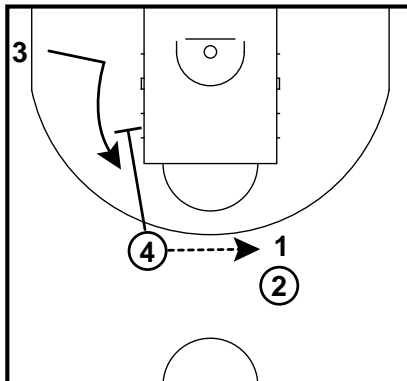

4 sentrer til førstemann i motsatt rekke og setter downscreen.  
3 trekker mann inn før han går av screenen  
1 og 2 vil sentre til hver av dem og bytte posisjon annenhver gang

2v0 Downscreens  
SO Offball screens

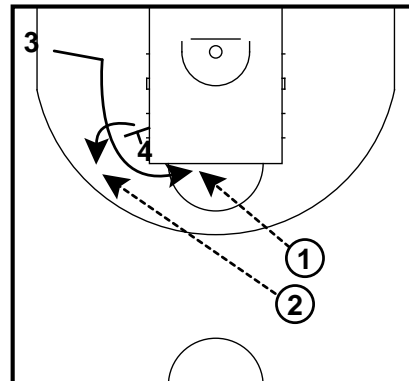

**Option 1:** 3 curler, 4 popper (motsatte bevegelser)

Forsvar: Tailer

2v0 Downscreens  
SO Offball screens

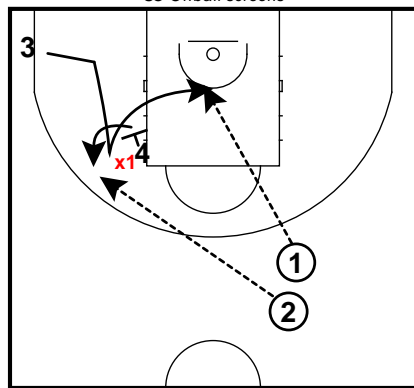

**Option 2:** 3 kutter backdoor, 4 popper (motsatte bevegelser)

Forsvar: Tailer

2v0 Downscreens  
SO Offball screens

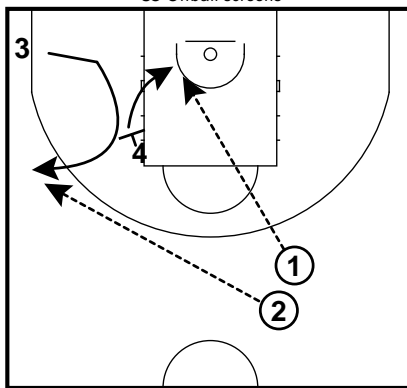

**Flare**

Forsvar: Går under screenen.

2v0 Shuffle cut  
SO Offball screens

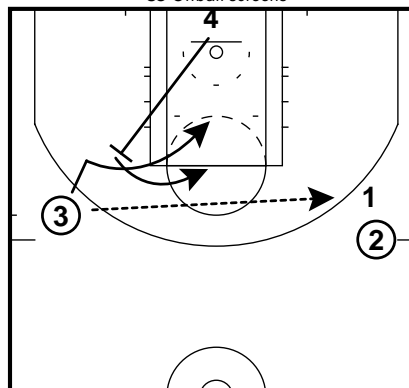

3 skipper ball over til 1, og mottar en screen fra 4. 3 Shuffle cutter mot kurv og mottar pasning fra 1. 4 popper mot straffelinje/3poengslinjen for skudd

2v0 UCLA Screen  
SO Offball screens

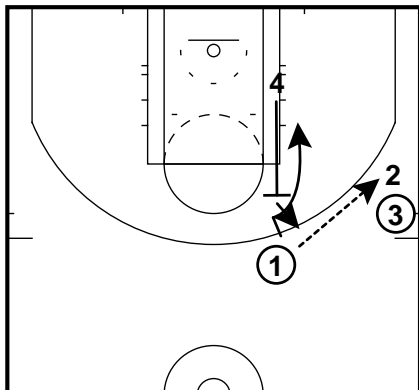

1 sentrer til 2, bruker screenen og får ballen tilbake av 2.  
4 setter screen for 1, popper etter screenen og får ball av 3 for skudd.

2v2 Backscreens  
SO Offball screens

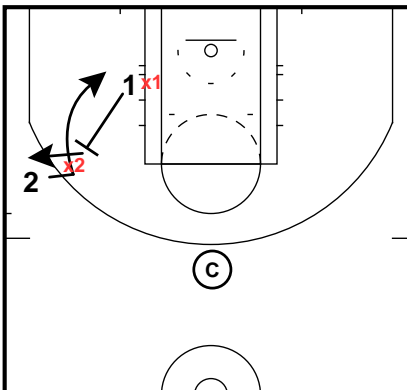

Spillere spiller 2v2  
**Mål:** lær å lede forsvarer i screen og skape scoringmuligheter fra action

2v2 Downscreen  
SO Offball screens

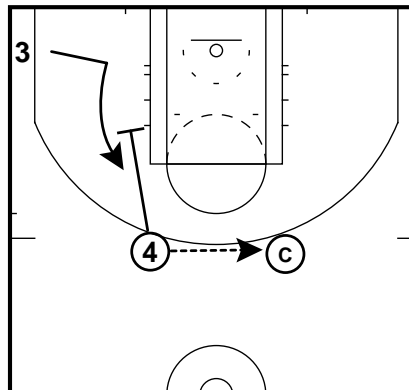

Spillere spiller 2v2  
**Mål:** lær å lede forsvarer i screen og skape scoringmuligheter fra action

# Screen vekk fra ball

3v3 baseline exit & cross screen  
SO Offball screens

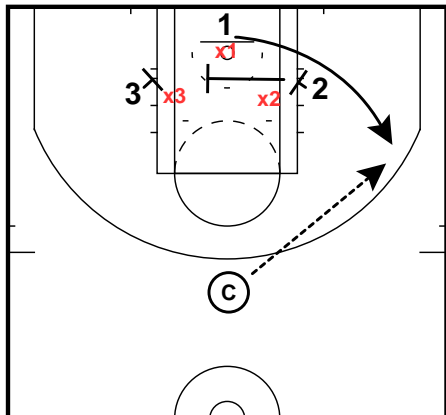

Spiller live  
1 går av screen på enten av sidene og gjør lesning.  
2/3 kan slippe til kurv dersom forsvar ikke følger med.  
Den siden 1 går av setter så cross screen for den andre.

Baseline Exit Shooting  
SO Offball screens

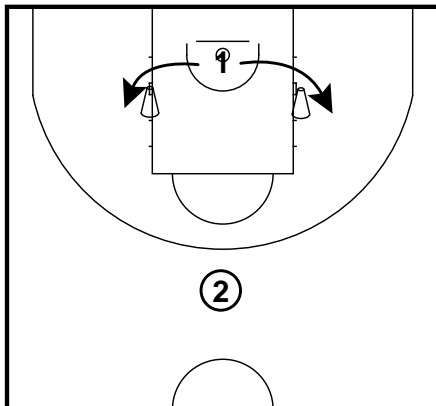

Spiller 2 på toppen med ball. Spiller 1 starter under ...

Baseline Exit Shooting  
SO Offball screens

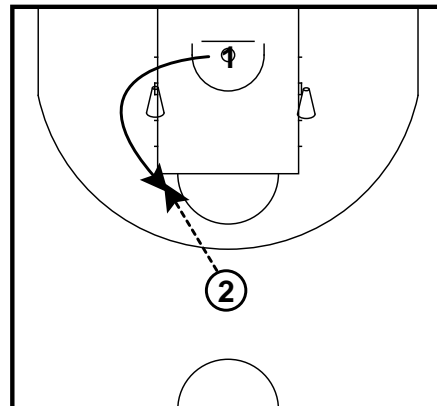

**Curl, Skuddlomme**  
Curle rundt kjeeglen, møte ballen rett inn i skudd. Stride stop.

Forsvar: Tailer (følger etter)

Baseline Exit Shooting  
SO Offball screens

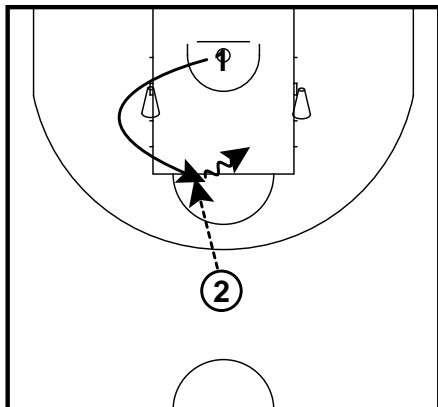

**Curl, Dribble, Floater**  
Samme situasjon, men fortsett curlen med én dribbling inn i stride stop og floater avslutning.

Forsvar: Tailer.

Baseline Exit Shooting  
SO Offball screens

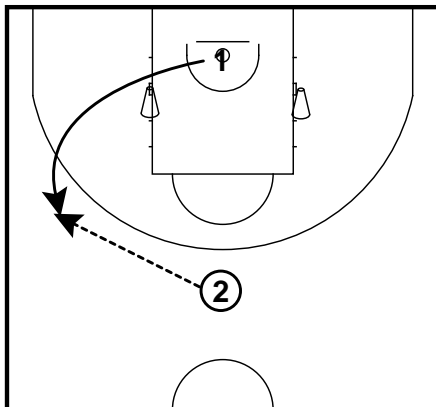

**Skuddlomme**  
Sprint av kjeeglen og skap så mye separasjon som mulig. Skyt 3-poenger.

Forsvar: Setter seg fast i screenen.

Baseline Exit Shooting  
SO Offball screens

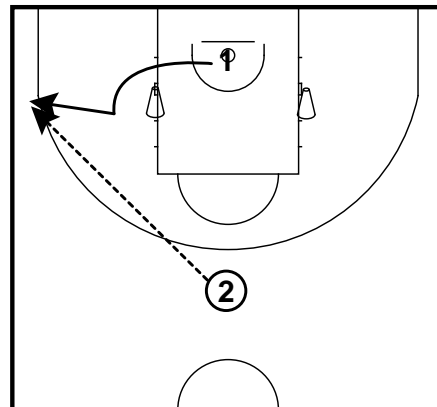

**Flare**  
Sprint av screenen. Skyv fra med innerste ben og skap separasjon. Møte pasningen i balanse.

Forsvar: Går på oversiden av screenen.

Baseline Exit Shooting  
SO Offball screens

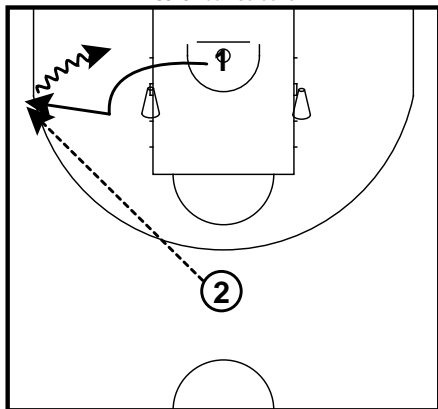

**Flare, Rip-n-Go**  
Samme situasjon, men istedenfor å skyte, riv ballen baseline 1 dribbling og skyt fra dribbling (pull-up).

Forsvar: Går på oversiden av screenen.

Down Screen Shooting  
SO Offball screens

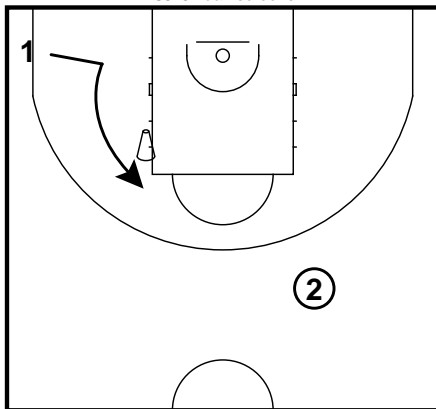

Nesten samme drill, men med en annen vinkling på screenen. Se Baseline Exit Shooting for detaljer.

Down Screen Shooting  
SO Offball screens

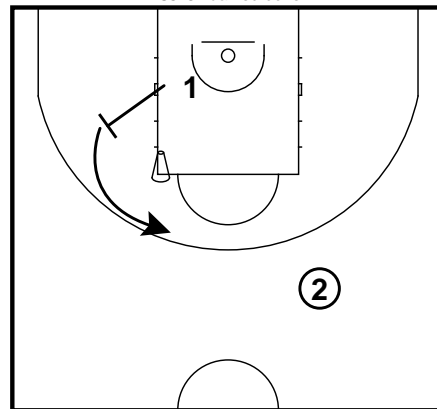

Kan gjøre samme drill, men starter med en back screen for å simulere vår shuffle situasjon i Open.

# Screen vekk fra ball

Down Screen Shooting  
SO Offball screens

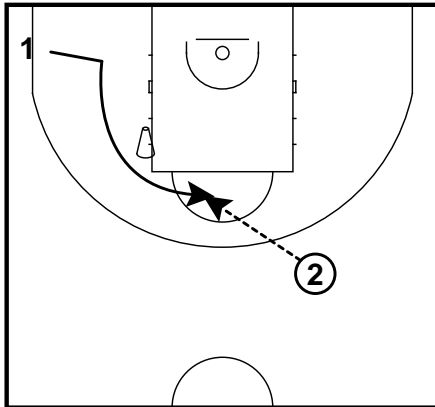

**Curl, Skuddlomme**

Forsvar: Tailer

Down Screen Shooting  
SO Offball screens

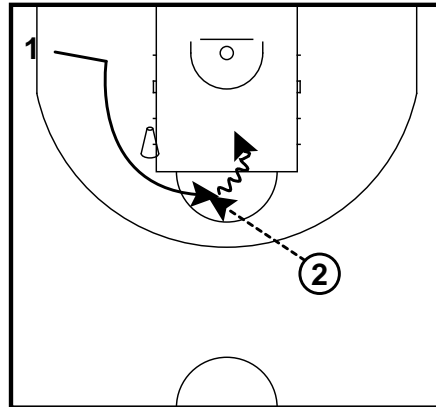

**Curl, Dribble, Floater**

Forsvar: Tailer

Down Screen Shooting  
SO Offball screens

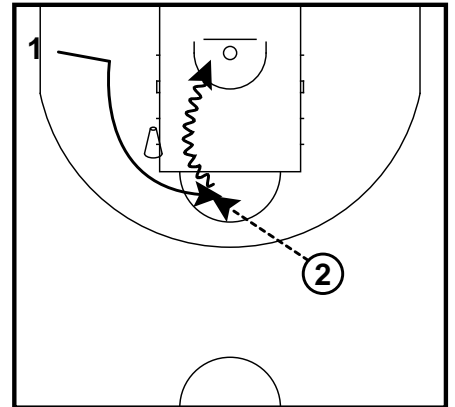

**Curl, Jump stop, Drive**

Curle rundt screenen. Stoppe i stride stop. En god skuddfinte. Drive i motsatt retning\_

Forsvar: Tailer

Down Screen Shooting  
SO Offball screens

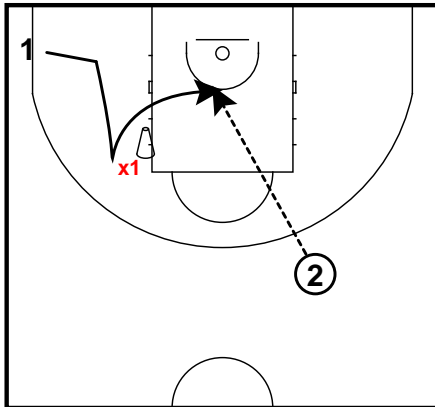

**Backdoor**

Forsvar: Jukser i gjennom screenen og havner på oversiden.

Down Screen Shooting  
SO Offball screens

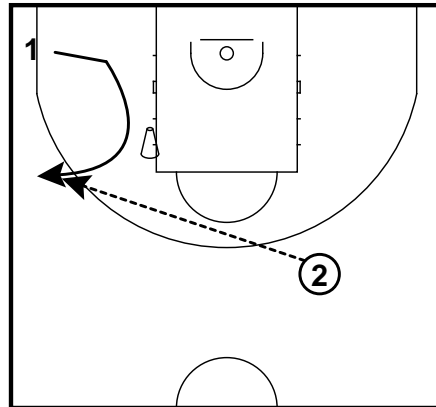

**Flare**

Forsvar: Går under screenen.

Down Screen Shooting  
SO Offball screens

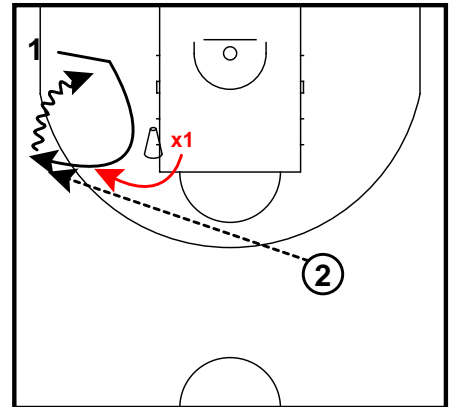

**Flare, Rip-n-Go**

Forsvar: Går under screenen

Down Screen Shooting  
SO Offball screens

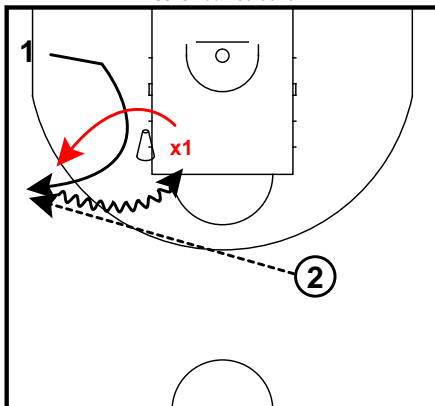

**Flare, Middle drive**

Forsvar: Går under screenen

Flare Screen Shooting  
SO Offball screens

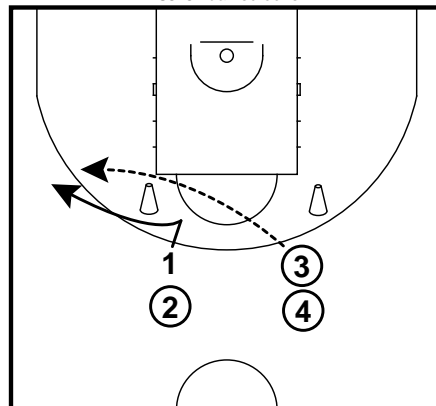

1 setter opp mannen sin og bruker flarescreen.  
3 sender passning over.

Forsvar: sitter fast i screen

Flare Screen Shooting  
SO Offball screens

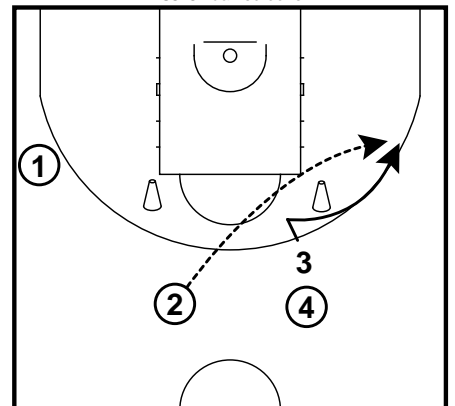

1 får scoringmulighet  
3 setter opp mannen sin og bruker flarescreen.  
2 sender passning over.

Forsvar: sitter fast i screen

# Screen vekk fra ball

Flare Screen Shooting  
SO Offball screens

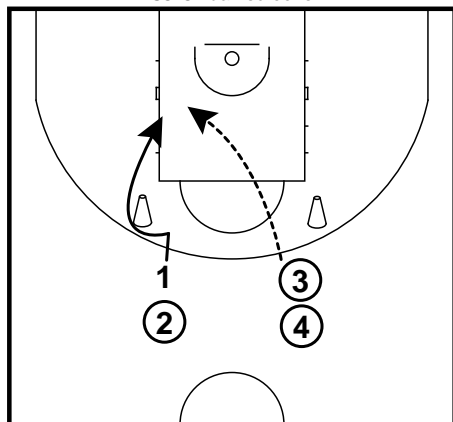

Kan også gjøres med curl variant.

Forsvar: Tailer



# Fastbreak

1v1 fastbreak (halfcourt)  
SO Fastbreak

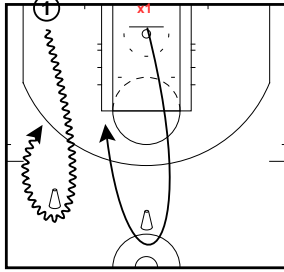

Spiller 1v1 i fastbreak sit. Begge løper fra innsiden og ut. Forsvaret starter å løpe når mann med ball starter.

2v1 + 1  
SO Fastbreak

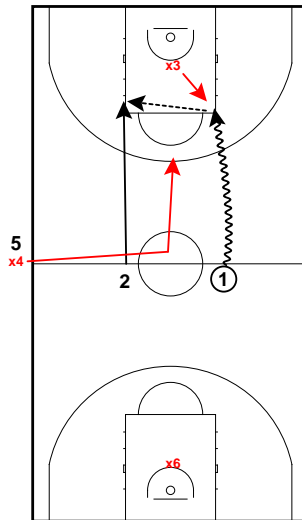

Play 2 on 1. When the ball crosses the half court an extra defender sprints into the mid circle and helps out in defense. If the offense does not find a quick shot it is 2 on 2. The offense and defense will fight for the rebound.

2v1 + 1  
SO Fastbreak

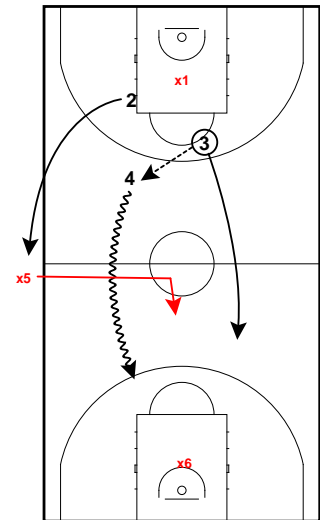

The two defenders X3 and X4 becomes offense and attacks the other way, where X5 will become the extra defender. One of the offensive players steps out (e.g. O2) and the second one stays in defense (e.g. X1).

**Options:**

- 1) divide into two teams (need 8 players).
- 2) on made baskets the offense may press full court until the ball crosses the half court.

2v1 Fastbreak (halfcourt)  
SO Fastbreak

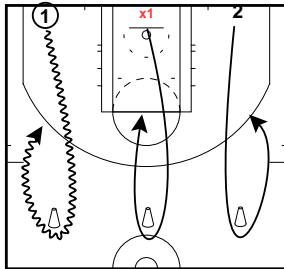

Spiller 2v1 i fastbreak sit. Begge angreppspillere løper innsiden og ut. Hold bredden og prøv å få scoring i 3 sek feltet

2v2 Trans  
SO Fastbreak

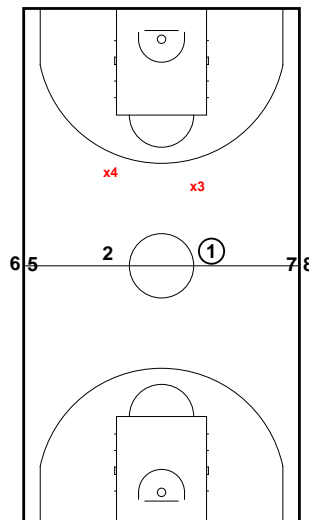

A 2 on 2 drill that focuses on transition defense. O1 and O2 plays 2 on 2 against X3 and X4.

**Purpose of the drill:** Defensive transition.

2v2 Trans  
SO Fastbreak

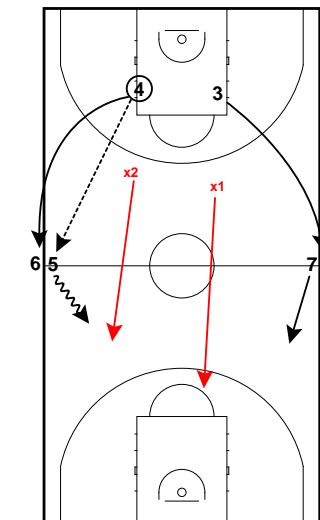

The offense always becomes defense. When they have lost possession of the ball they must sprint back on defense to 1) pressure the ballhandler and 2) protect the basket. The previous defense (players 3 and 4) outlets the ball to one of the lines at mid-court. They will both get back in line.

The new offense are not allowed to run into offense before the offense (O5 in the diagram) has touched the ball. In other words the offense are not allowed to cheat! Its now 2 on 2 again on the other side.

# Fastbreak

3v0 break options  
SO Fastbreak

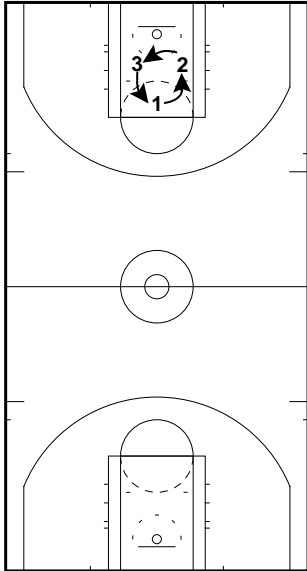

Spillere løper i sirkel, coach kaster opp ball og spillere tar rebound.

3v0 break options  
SO Fastbreak

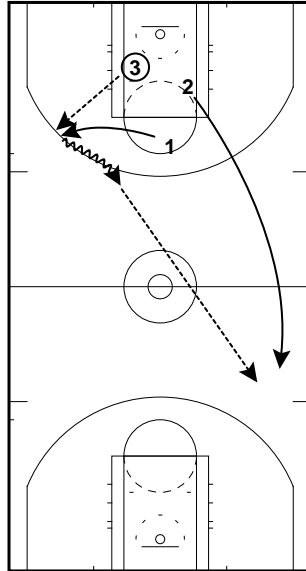

Om mulig, push the ball up the court og layup

3v0 break options  
SO Fastbreak

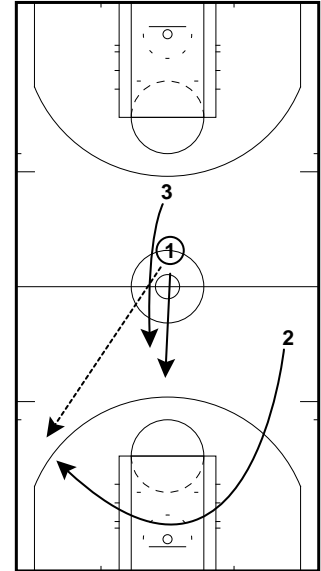

Dersom 2 ikke får ball kutter den gjennom painten og ut på motsatt ving. fullfør med break options

3v0 break options  
SO Fastbreak

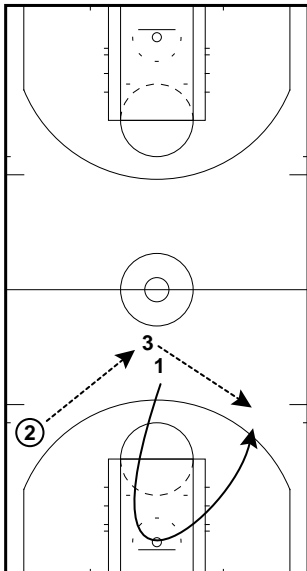

Eks: kutt igjennom, reverser og screen motsatt

3v0 break options  
SO Fastbreak

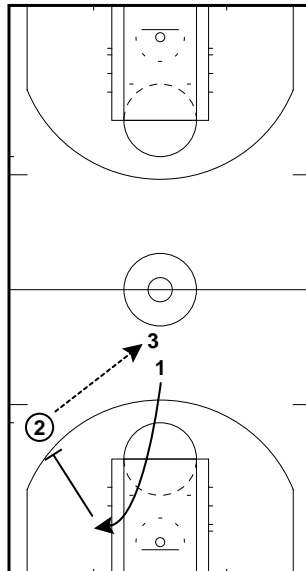

Eks: 1 kutter strongside post, 2 svinger ballen tilbake til 3.  
1 setter deretter en backscreen

3v2 + 1  
SO Fastbreak

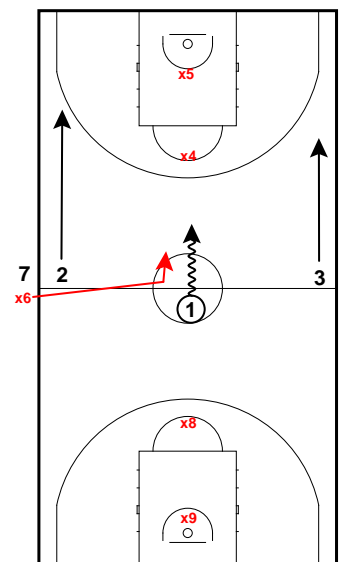

Same drill as 2 on 1 + 1, but with extra players to get 3 on 2 and 3 on 3. The offense will try to get an easy basket early, if not slow down and play half court offense 3 on 3.

**Options:**

- 1) divide into two teams (need 12 players).
- 2) on made baskets the offense may press full court until the ball crosses the half court.

# Fastbreak

3v3 break options  
SO Fastbreak

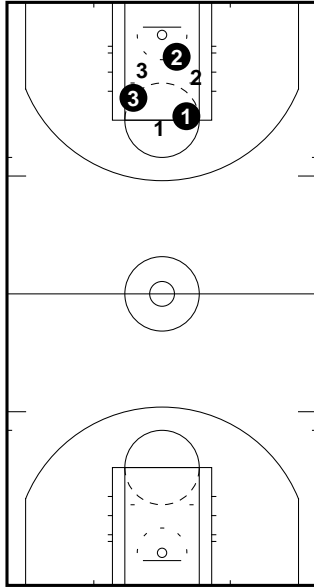

Samme som 3v0, men nå kjemper de om rebound og spiller mot hverandre.

3v3 Pheonix  
SO Fastbreak

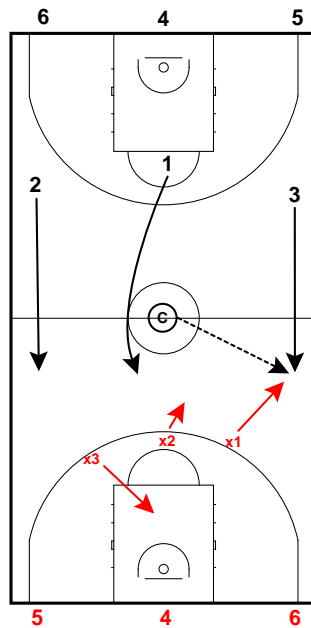

To lag. Coach i midten. Etter scoring eller turnover skal angrep i forsvar.

**Kommentar:** Gjør den samme drillen 4v4 hvis mange spillere.

3v3 Pheonix  
SO Fastbreak

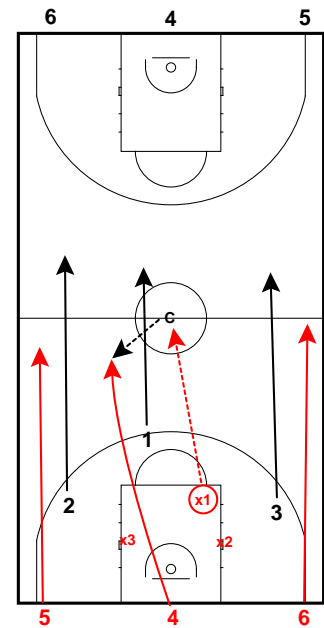

Forsvaret må få tak i ballen og sentre til coach. Laget på baseline sprinter opp i angrep og mottar ballen fra coach. Samme på andre siden.

**Forsvar:** Plukke opp ballfører. Beskytte kurv. Nekte pasning opp langs siden.

**Angrep:** Defensiv balanse. Tolmodighet og valg.

4v3 + 1  
SO Fastbreak

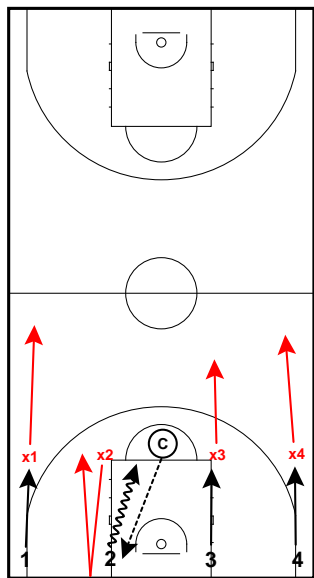

Coach passes to one of the offensive player on the baseline. The corresponding defender must sprint and touch the baseline before sprinting back in defense.

Outlets 2v0  
SO Fastbreak

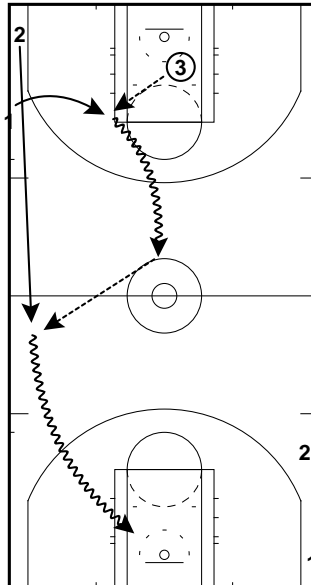

3 tar retur og sender outlet pasning til 1. 1 tar ballen og dribbler opp banen frem til 2 passerer. 2 starter å sprinte ytterste lane når 3 får kontroll på retur. Får pasning fra 1, driver på kurv og fullfører.

Den som ikke legger layup er returtager og sender outlet pasning

Outlets 2v0  
SO Fastbreak

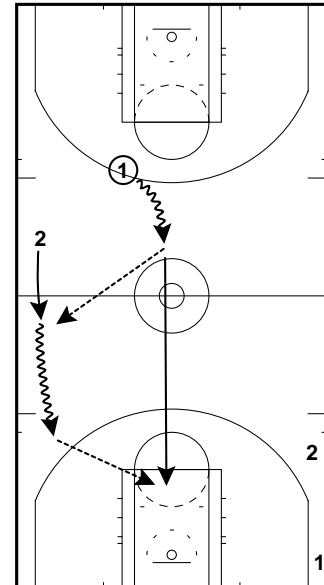

Samme drill, men nå blir 2 "stoppet" og hiver pasning tilbake til 1 som kutter mot kurven

# Fastbreak

Outlets 3v0  
SO Fastbreak

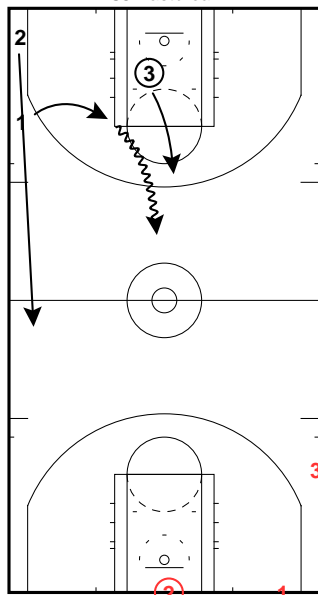

1 kommer for outlet og pusher ballen opp banen med passning til 2.  
2 løper når 3 tar returen.

Outlets 3v0  
SO Fastbreak

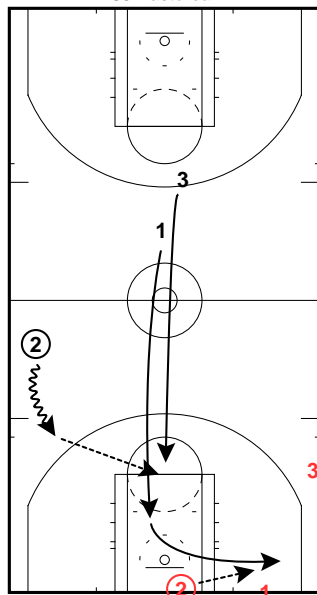

Etter å ha sentret til 2 kutter 1 mot kurven, mottar ikke ball og kutter til weakside. her får 1 passning og skudd.  
3 kommer som second trailer og mottar passning fra 2

(få 2 til å krasje på retur for 1)

Outlets 3v0  
SO Fastbreak

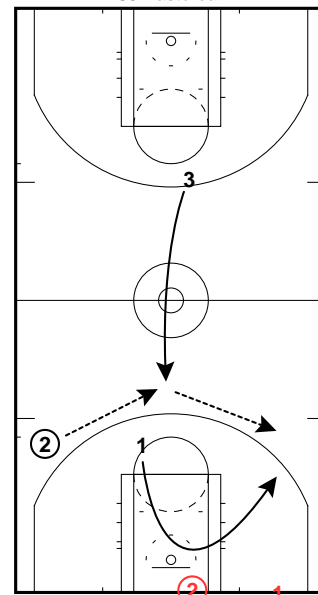

Progresjon kan man reversere ballen inn i secondary break

Outlets 3v0  
SO Fastbreak

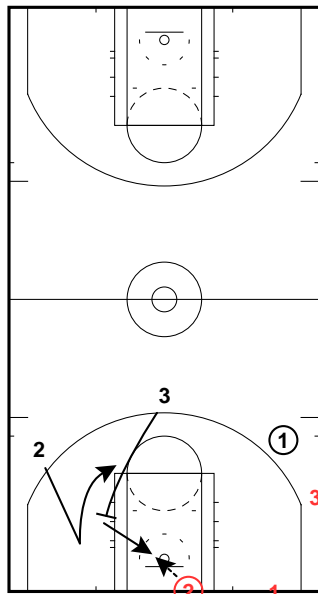

3 kan screene motsatt eller sette pindown og slipe screenen.  
2 kommer av screenen og får ball fra 1.

Transition build-up  
SO Fastbreak

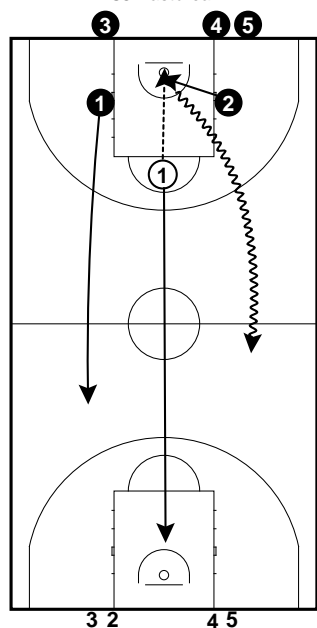

To lag. 2v1, 3v2, 4v3, 5v4 til 5v5. Starter med straffeskytter + to reboundere. Etter rebound er det 2 mot 1. Etter 2 mot 1 vil forsvarlaget få inn to nye spillere til 3 mot 2 (angrep tilbake i forsvar). Fortsetter opp til 5 mot 5.

**Kommentar:** på U14 spiller vi kun til 4 mot 4.

Transition build-up  
SO Fastbreak

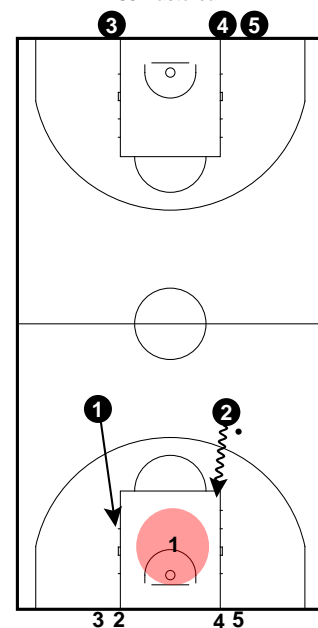

**2v1**

**Forsvar:** Beskytte kurven. Stunte/fake. Aktiv. Ingen lay-ups!

**Angrep:** Spacing. Så lenge det er en "lane" til kurven, angrip helt til forsaret engasjerer seg.

# Fastbreak

Transition build-up  
SO Fastbreak

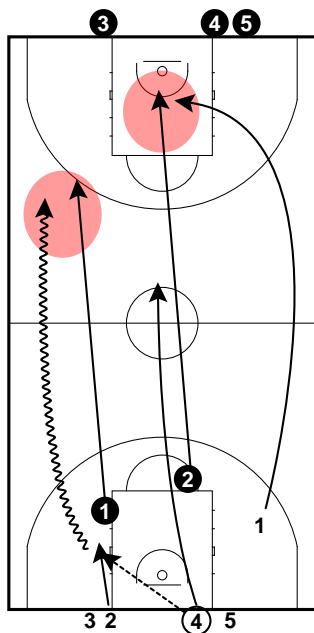

3v2

**Forsvar:** Dekke ball og kurv (low hole). Sprinte til posisjoner.

**Angrep:** Sprinte korridorer. Engasjere en forsvarer for å skape overtall motsatt. Angripe kurven uten ball (se spiller 1).

Transition build-up  
SO Fastbreak

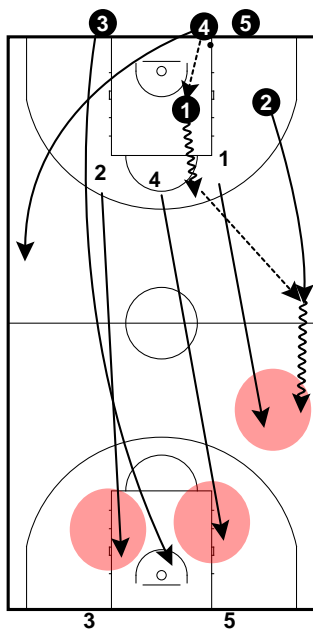

4v3

**Forsvar:** Dekke ball, low og high hole. Nærmeste mann-prinsippet. Match-up fra innsiden og ut.

**Angrep:** Sprinte korridorer. Høyre, venstre og første trailer til kurven. Ball bevegelse. Tolmodighet - La ballen gjøre jobben.

Transition build-up  
SO Fastbreak

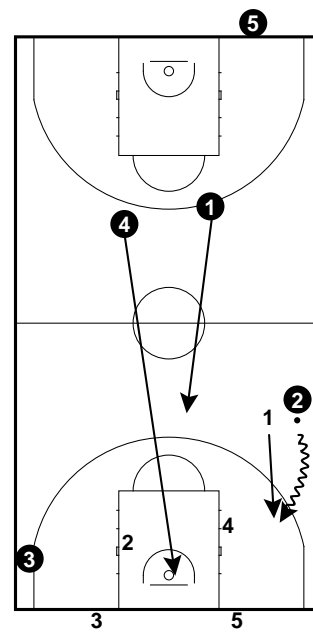

Transition build-up  
SO Fastbreak

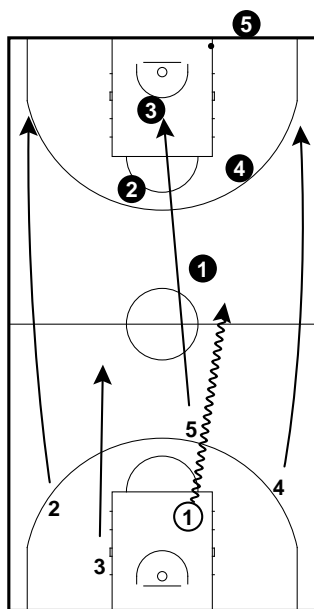

5v4

Samme som 4v3.

Transition build-up  
SO Fastbreak

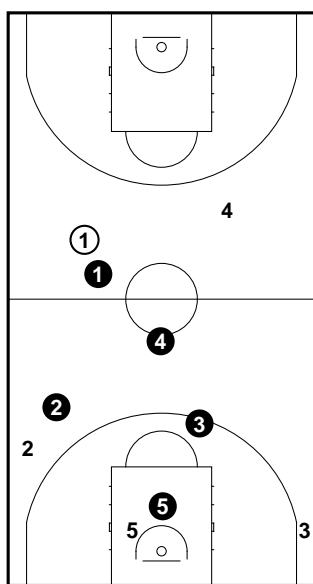

5v5

# Defensive Skills

1v1 jump to the ball & deny  
SD Defensive skills

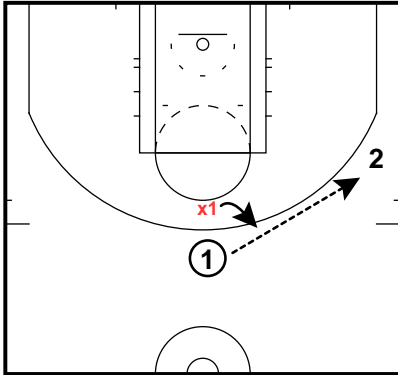

Når 1 sentrer er det live.  
x1 skal da hoppe til ballen og overspille.  
1 skal prøve å kutte på kurv og få ballen.

1v1 Weak  
SD Defensive skills

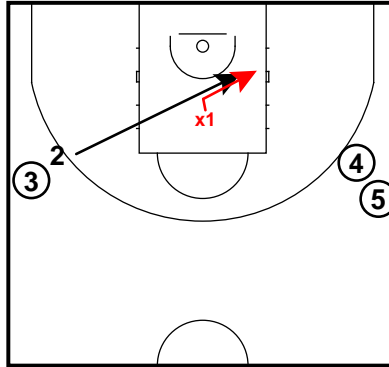

Two lines with offensive players, and one defender in ...

1v1 Weak  
SD Defensive skills

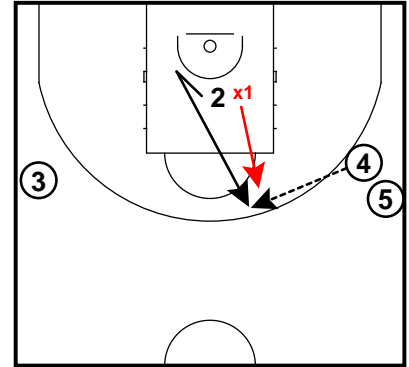

If not O2 is open on the cut he must get open either at the top, in the post or in the corner. Remember that X1 must follow our defensive principles on where to deny and open up. If O2 ever gets the ball, the game is live 1 on 1. The players must work on the rebound.

1v1 Weak  
SD Defensive skills

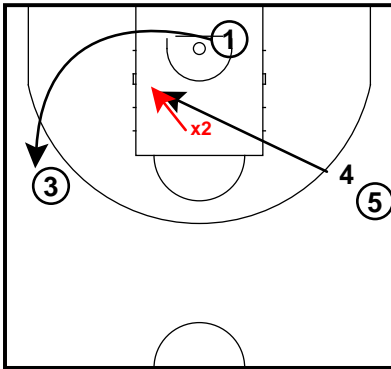

**Rotation:** When the game is finished player 2 becomes defense (X2), and player 1 takes the ball and steps out. The drill starts over with the weak side cut from the other side.

closeouts and slides  
SD Defensive skills

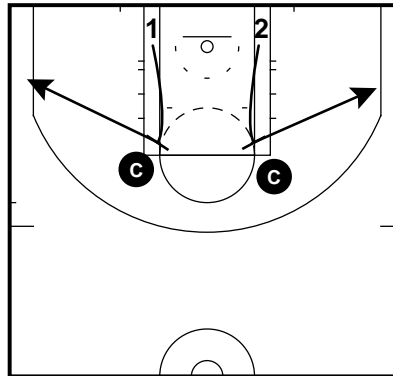

1 og 2 sentrer til coach, closer ut og slider til sidelinje

NBA closeout  
SD Defensive skills

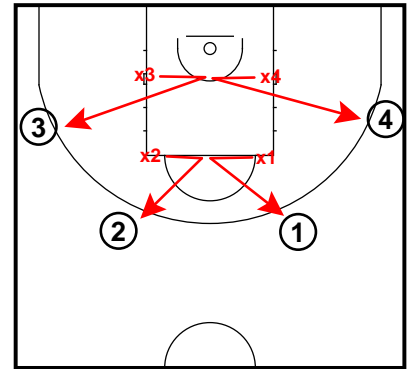

På fløyta, high 5 inn mot midten, closeout på spiller. Offensiv spiller pivoterer, ball høyt og lavt. Forsvar spiller ballen og justerer posisjon.

**Nøkkelpunkter:** Armelengde når offensiv er i trippel trussel. Crowde når ball er over hodet. Nese på ball = posisjon. Ta vekk midten!

NBA closeout  
SD Defensive skills

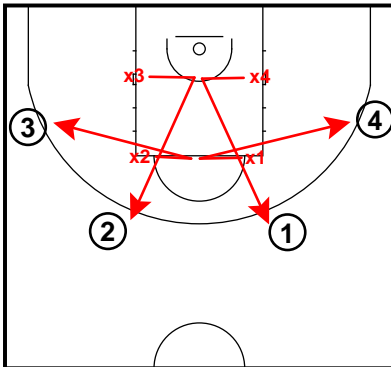

Samme, men med X-out mønster. Simulere en "help-the-helper" situasjon hvor forsvar må bytte mann.

NBA closeout  
SD Defensive skills

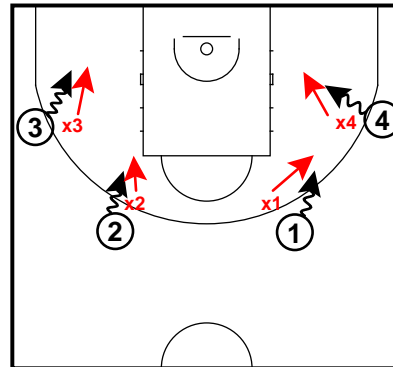

Legg til dribbling på fløyte. 1-2 sprett. Forsvar tar vekk midten. Offensiv spiller plukker opp ball og død situasjon = crowde! Fokus på å vise hender, ingen reach in.

# Hjelpeforsvar

2v2 help and closeout  
SD Hjelpeforsvar

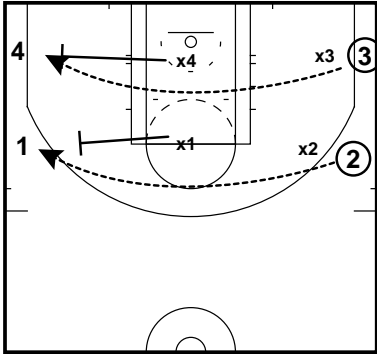

angrep skip passer frem og tilbake, forsvar roterer og closer ut

2v2 Help the helper & closeout  
SD Hjelpeforsvar

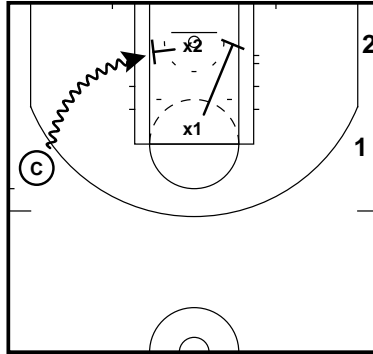

Hjelpeforsvar står på splitline klar for å hjelpe. Når Coach driver stepper x2 over og x1 dropper.

2v2 Help the helper & closeout  
SD Hjelpeforsvar

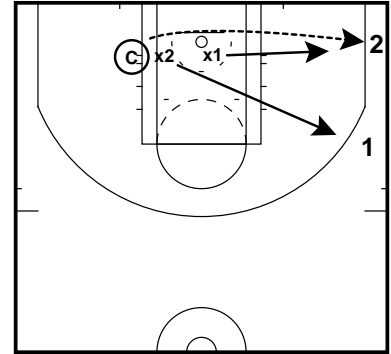

Coach spiller ball videre til motsatt side. x1 må close ut på den som mottar ball, x2 tar neste mann. 2v2 live herfra

2v2 Hip  
SD Hjelpeforsvar

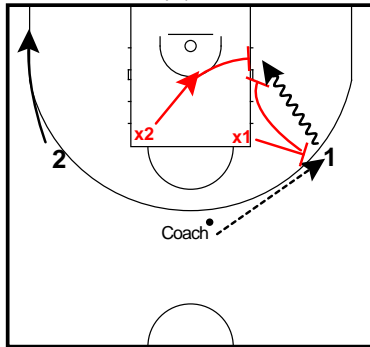

"Tvungen" baseline drive m / wk drift. Stunt utenfor 3 sek, retreat dri og pasning tilbake til coach. Live på neste pasning.

2v2 Hip  
SD Hjelpeforsvar

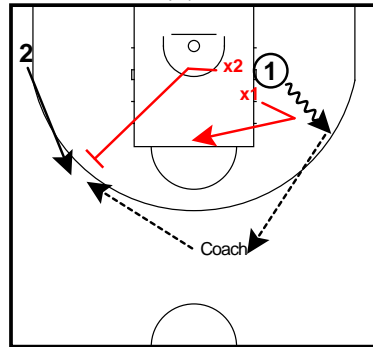

X2 closeout og ta vekk midten. Live 2v2.

3 on 3 stunt  
SD Hjelpeforsvar

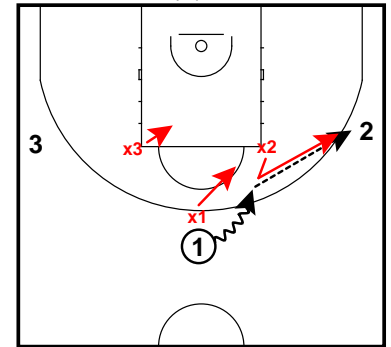

The ball starts in the middle, with two wings. The defense pressure the ball and pinch in on the elbows. The first two drives are dummy defense. On the second drive and kick the game is live 3 on 3.

**Purpose of the drill:** Work on protecting the elbows when the ball is in the middle by stunting on middle drives and recover.

3 on 3 stunt  
SD Hjelpeforsvar

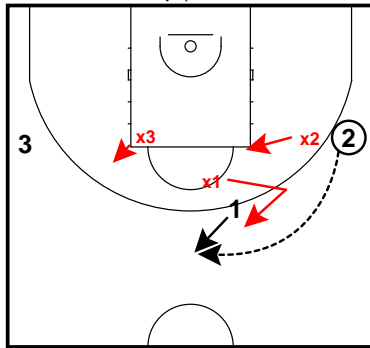

Close out to positions when the ball is passed back.

3 on 3 stunt  
SD Hjelpeforsvar

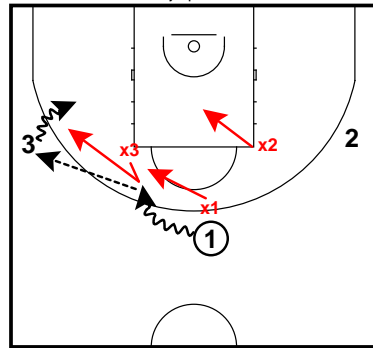

When O3 gets the ball the game is live 3 on 3.

3v3 Hip  
SD Hjelpeforsvar

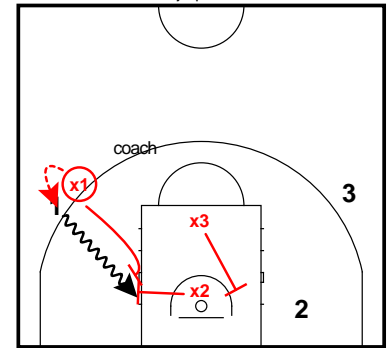

Starter med 1 får ball av X1, driver mot kurven. X2 stunter, X3 dropper ned (hjelper hjelperen).

# Hjelpeforsvar

3v3 Hip  
SD Hjelpeforsvar

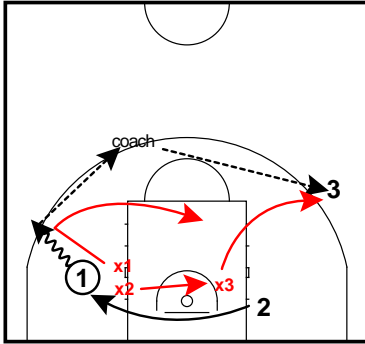

1 retreat og pasning til coach. Coach svinger til 3. Forsvar hopper mot ballen. X3 closer hardt ut på 3 og tar vekk midten. Live!

**Merk:** 2 sirkler under til weak side.

3v3 Post defense  
SD Hjelpeforsvar

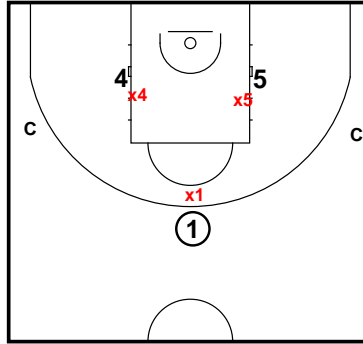

The offense (including the coaches) passes around outside the 3-point line. The defense must rotate to correct positions, and the offense may either stand still or rotate in a given way. The coaches may pass inside to the post. If so the game is live 3 on 3.

**Purpose of the drill:** Work on post defensive positions and rotations.

3v3 Post defense  
SD Hjelpeforsvar

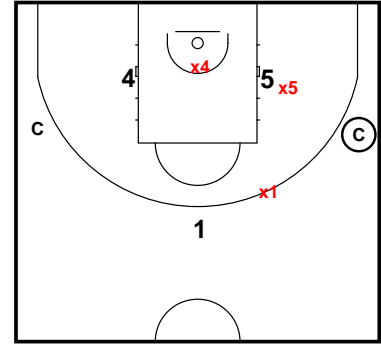

When the ball is on the side we front the strong side post in "deep position" and help in "low position".

3v3 Post defense  
SD Hjelpeforsvar

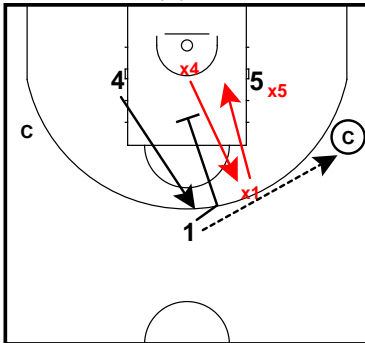

**Drill 1: Down screen**

When the top passes to a coach he will down screen the weak side post. Defend the screen either by switching or going through.

3v3 Post defense  
SD Hjelpeforsvar

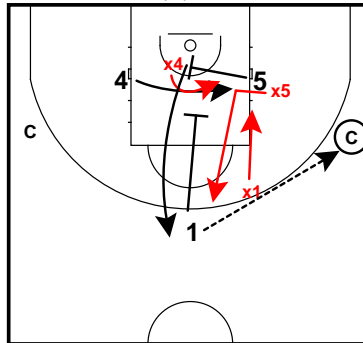

**Drill 2: Cross screen + down screen**

When the top passes to a coach the strong side post will cross screen, and the top will screen the screener.

3v3 Skip, Closeout, Stunt, Help the Helper  
SD Hjelpeforsvar

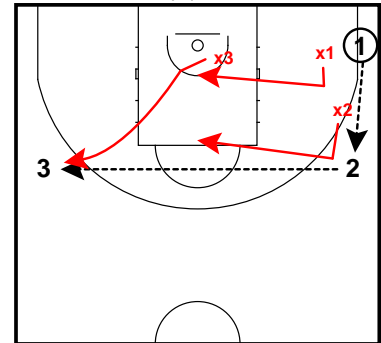

3v3 Skip, Closeout, Stunt, Help the Helper  
SD Hjelpeforsvar

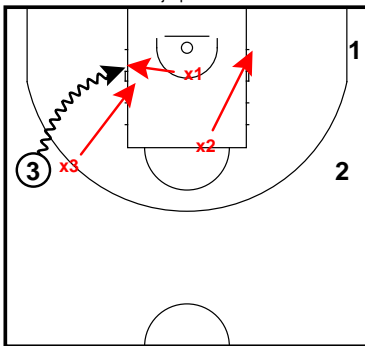

3v3 Stunt, Reverse, Closeout  
SD Hjelpeforsvar

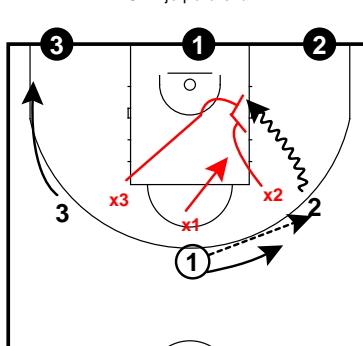

3m3.. ballen starter på topp og må sentre... tvungen baseline drive, stutes utenfor 3 sek.

3v3 Stunt, Reverse, Closeout  
SD Hjelpeforsvar

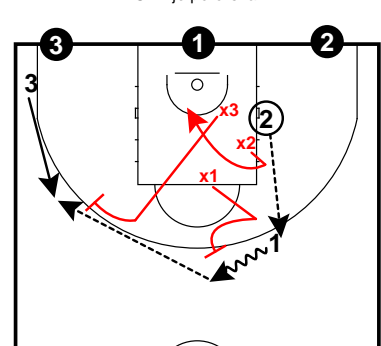

Ballen reverseres til motsatt ving.

Live fra vingen.



# Hjelpeforsvar

4 m Shell - Baseline drive  
SD Hjelpeforsvar

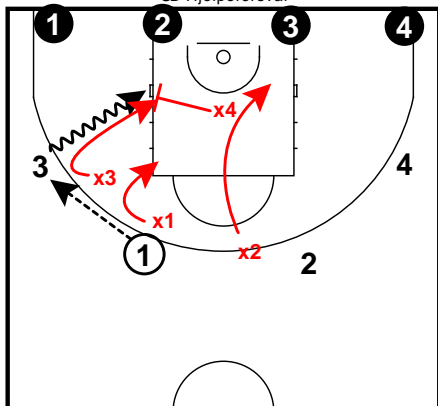

Ingen kutter, kun defensiv posisjonering. Rip & go når ballen kommer til vingen. Forsvar tar vekk midten og trykker ballen ned mot hjørnet. Stunt fra low og rotasjon ned fra high til low (hjelp hjelperen).

4 m Shell - Baseline drive  
SD Hjelpeforsvar

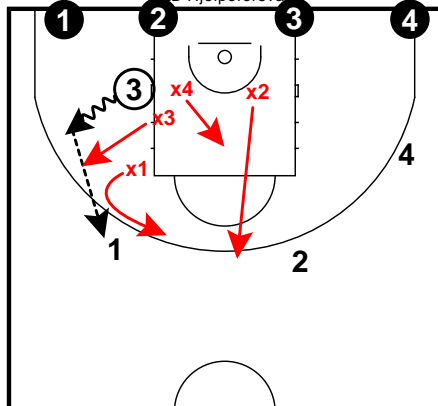

4 m Shell - Baseline drive  
SD Hjelpeforsvar

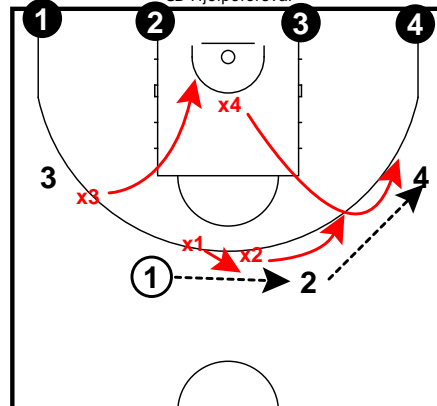

4 m Shell - Down Screen  
SD Hjelpeforsvar

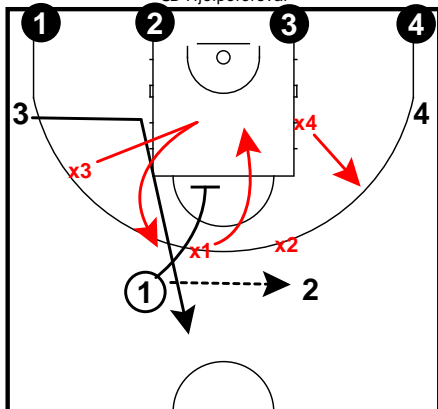

Down screen etter pasning fra guard til guard pasning.

D = Hoppe til ball. Plugge low. X3 enten klemme seg i mellom screen og 3, eller i mellom screen og X1. X1 må gi rom.

4 m Shell - Flare screen  
SD Hjelpeforsvar

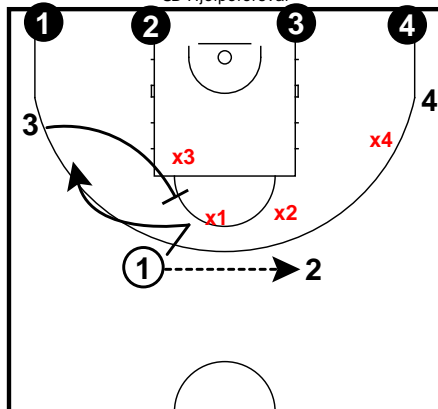

Flare screen etter guard til guard pasning.

D = screen forsvarer åpner opp og plugges en tight curl. Kutt forsvarer klemmer seg mellom screenen og kutteren. Forsøker og komme seg i ballbanen.

4 m Shell - Strong side cut  
SD Hjelpeforsvar

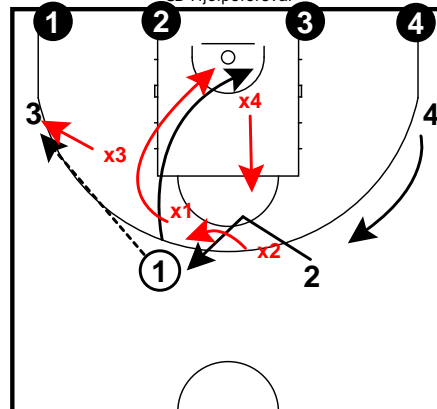

Guard til ving pasning = kutter til kruven. Forsvaren hopper mot ball. Overtar low hole. Lowhole tagger kutter før en blir high hole.

4 m Shell - Weak side cut  
SD Hjelpeforsvar

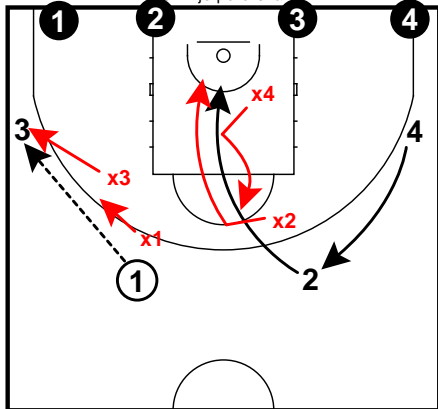

Pasning guard til ving. Motsatt guard kutter til kurven. Bumpes av high hole. Low hole tagger kutteren før blir high.